

RTD-W

Installation Instructions

English RTD-W Installation Instructions

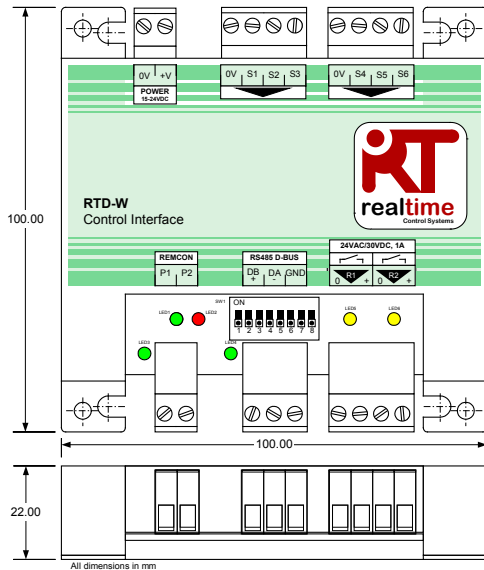

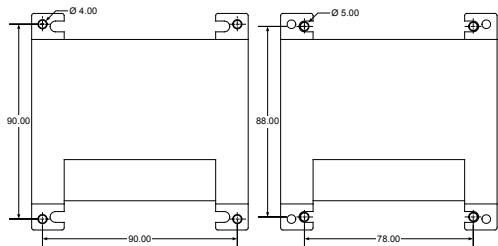

1

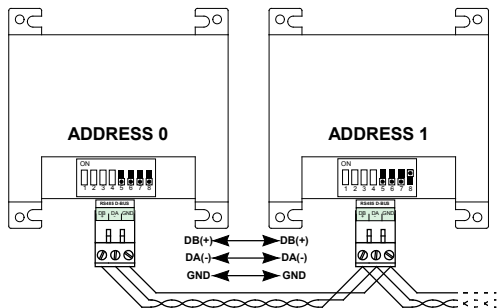

4

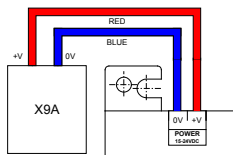

2

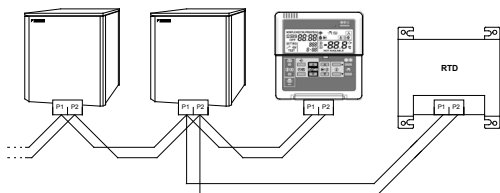

3

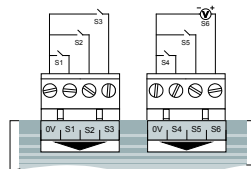

5

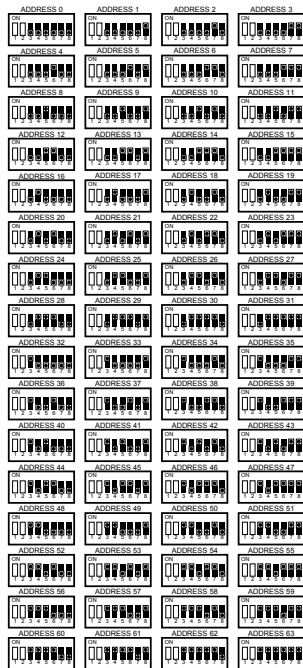

6

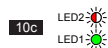
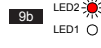

Warnings and Cautions

Do not exceed the specified fault relay ratings (maximum 1A, 24VAC/30VDC). Relays not intended for connection to safety critical equipment.

All cable connections to the device must be adequately secured by suitable strain relief fasteners

The RTD must either be mounted in a suitable metal enclosure or plastic enclosure with a flammability rating of at least IEC60695-11-10 V-1. Do not install it inside the air-conditioning unit. In all cases access by non-qualified persons must be prevented (the enclosure may not be accessible without a tool). The unit can be mounted horizontally or vertically

When the RTD is powered from the indoor unit power supply or other non-SELV supply, all external wiring and electrically attached devices must be suitably insulated to prevent access by non-qualified persons. Where this is not possible, the RTD must be powered from an SELV supply.

RS485 Cables must use stranded 24awg shielded or unshielded twisted pair to Cat3, Cat4 or Cat5 specification. Use a twisted pair for connections DB,DA and an extra core for connection GND. Install RS485 cable as shown in Figure 4.

The P1,P2 Network must be connected as shown in Figure 3. Up to 16 units and one remote controller can be connected to the RTD.

When connecting voltage signal from external sources to input S6, 0V line must be connected to earth external to the RTD.

S1 to S6 cables must be 0.5 to 0.75 mm² multi-stranded screened twisted pair. The screen must be earthed at one end only. The maximum distance from the RTD to the input source is 200m.

Specifications

Electrical

Supply	15V-24V DC, 120mA Regulated
Power	<2.5VA
Relay	1A, 24VAC max 1A, 30VDC max
Connectors	Rising clamp to 0.75mm ² cable

Network

P1P2	<1m
RS485	<500m

Environmental

Temperature

Storage -10oC to 50oC

Operation 0oC to 50oC

Humidity

0-90% RH
non-condensing

Inputs

Voltage Mode	S1..S6	0..10VDC
	<1mA	
	Maximum	Rating
	12VDC	

Resistance Mode S1..S6 5V, 1mA

Pulse Maximum 10Hz



Your product is marked with the symbol shown to the left. This symbol on the product indicates that this product must not be disposed of with your other household waste. Inappropriate disposal may be harmful. Instead, it is your responsibility to dispose of your waste equipment by handing it over to a designated collection point for the recycling of waste electrical and electronic equipment. Units must be treated at a specialized treatment facility for re-use, recycling and recovery. By ensuring this product is disposed of correctly, you will help to prevent potential negative consequences for the environment and human health. Please contact the installer or local authority for more information.



Observe precautions for handling Electrostatic Sensitive Devices

Additional information, including Modbus configuration and Fault Codes are available from www.realtime-controls.co.uk/rtd

Installation Instructions

The RTD-W is a monitoring and control interface for Atherma HT hydroboxes (heating only and reversible), small inverter chillers (EWA/YQ16..64 series) and VRV heating only hydrobox. The interface is compatible with all units that are operated using a BRC21 remote controller network connection and allows control of up to 16 units in a single group.

MOUNTING (FIGURE 1)

MOUNTING PILLARS

The RTD-W is supplied with 4 mounting pillars that can be used to mount the interface within units with compatible mounting holes

SCREW MOUNTING

The RTD-W can be mounted using screws of up to 5mm diameter.

POWER SUPPLY (FIGURE 2)

The RTD requires a 15V to 24VDC power connection. Power can be supplied from the X9A connection at the A3P PCB. A 1m cable and connector is supplied with the RTD-W. If the power supply is taken from the X9A, limitation of options is possible.

P1,P2 NETWORK (FIGURE 3)

Terminals P1, P2 connect to the P1, P2 network. P1,P2 installation must follow installation specifications. The RTD-W operates in SUB mode with a BRC21 remote controller configured as MAIN.

A 1m cable is supplied with the RTD-W. See hydrobox instructions for number of controllers that can be connected to P1P2, the RTD counts for 1 BRC controller

RS485 NETWORK INSTALLATION (FIGURE 4)

The RS485 D-Bus network requires a twisted pair cable connecting terminals DB(+) and DA(-) on each RTD as shown below. Terminal DB must be connected to all other DB terminals. Terminal DA must be connected to all other DA terminals. In addition the common terminal GND on all devices must be connected together. If a shielded cable is used then the shield can be used for this purpose. It is recommended that the GND connection is connected to local Earth at one point only. The network must be installed as a daisy-chained point-to-point Bus configuration, Star and Ring connections must NOT be used.

RS485 NETWORK LENGTH

Standard installation for total network distances of up to 500m can be achieved following the basic daisy-chaining method showed in the above diagram. The network can be extended further using RS485 repeaters.

LED FUNCTIONALITY

When the RTD-W is powered up, or if it loses communication with the Remote Controller the RTD-W enters P1,P2 search mode. If P1,P2 communications are not re-established after 1 minute the RTD-W will raise an alarm which will be indicated on the fault relay output. Led behaviour is shown in the following figures

Power-Up sequence: Factory Configuration	Figure 8a
Power-Up sequence: Custom Configuration	Figure 8b
P1,P2 Search. After power-up and during unit configuration	Figure 8c
No Fault State	Figure 9a
Unit Fault	Figure 9b
Device configuration error	Figure 10a

AC Unit Missing (U5 Fault)	Figure 10b
RS485 Communications timeout	Figure 10c

LED Key:

<input type="radio"/> OFF	 ON	 Flashing
---------------------------	--	--

ADDRESSING

The RTD-W has the facility to create control groups using multiple RTDs connected together on the RS485 D-Bus network. In standard configuration up to 64 RTD-W devices can be connected together. Each RTD is assigned a D-Bus address using the configuration switches SW1.3 to SW1.8. (FIGURE 6).

UNIT SEARCH

When the RTD-W is powered up, or if it loses communication with the Remote Controller the RTD-W enters P1,P2 search mode. If P1,P2 communications are not re-established after 1 minute the RTD-W will raise an alarm which will be indicated on the fault relay output.

RTD-W STANDARD INPUTS

Inputs S1 to S6 are wired between the labelled Sensor terminal and the 0V terminal on the same connector block (Figure 5).

S1 to S6 cables must be 0.5 to 0.75mm² multi-stranded screened twisted pair. The screen must be earthed at one end only. The maximum distance from the RTD-W to the input source is 200m.

It is recommended that volt-free contacts or switch mechanisms have gold plated contacts to ensure a low resistance circuit when the switch is made.

STANDARD CONTROL



For Standard Control operation, SW1.1 and SW1.2 should be OFF.

Input	Name	Range (default)
S1	Space Heating On	On Open Circuit: Heating OFF On Closed Circuit: Unit ON and Heat Mode
S2	Space Cooling On	On Open Circuit: Cooling OFF On Closed Circuit: Unit ON and Cool Mode
S3	DHW Reheat Disable	<u>Open Circuit: DHW Reheat Enable and Restore DHW On/Off state after DHW Reheat Disable</u> Closed Circuit: DHW Reheat Disable
S4	Enable Quiet Mode	<u>Open Circuit: Quiet Mode Disable</u> Closed Circuit: Quiet Mode Enable
S5	SPARE	<u>Not In Use</u>
S6	Leaving Water Heating/Cooling Setpoint	<u>Open Circuit: Not Active</u> 1~10VDC : On Voltage Change set Leaving Water Heating/Cooling Setpoint

Output	Name	Operation
R1	Heating/Cooling	Closed on Space Heating/Cooling operation
R2	Fault	Unit Fault Condition

Space Heating ON (S1) Input S1 will switch the unit into Space Heating and switch the unit ON when the input becomes closed-circuit. If the input becomes open-circuit then the space heating will switch OFF. After an ON or OFF pulse has occurred the unit can be manually adjusted using the Remcon.

Space Cooling ON (S2) Input S2 will switch the unit into Space Cooling and switch the unit ON when the input becomes closed-circuit. If the input becomes open-circuit then the space cooling will switch OFF. After an ON or OFF pulse has occurred the unit can be manually adjusted using the Remcon.

DHW Reheat Disable (S3) When input S3 is closed-circuit the operation of DHW Reheat is disabled and cannot be activated from the Remcon. When input S3 is open-circuit DHW can be operated normally. After Reheat Disabled operation, when input S3 becomes open-circuit the DHW on/off state is restored to the same condition as before DHW Reheat Disable occurred.

Enable Quiet Mode Operation (S4) When input S4 is closed-circuit the Quiet Mode function is activated and the unit will operate according to the Quiet Mode restrictions. When input S4 is open-circuit the unit will operate with no restriction.

Leaving Water Heating/Cooling Setpoint (S6) An input voltage of 1~10VDC applied to input S6 will set the current leaving water heating or cooling setpoint when the voltage input changes by more than 0.1V, and the input voltage corresponds to a valid setpoint in the current mode of operation. Input S6 is active if the input is at least 1.0VDC. If the input has a value of <0.5VDC or is open-circuit then the input function is disabled.

Table of S6 Input Voltages

Voltage V	1.0	2.0	3.0	4.0	5.0	6.0	7.0	8.0	9.0	10.0
Setpoint °C	-10	0	10	20	30	40	50	60	70	80

Voltage input is accurate to 0.1V, allowing the setpoint to be defined to the nearest 1°C.

Therefore a voltage of 4.5V corresponds to a setpoint of 25°C.

The following limits are defined for different operating modes and models. Voltages set outside of these limits will not change the setpoint.

Inverter Chiller	Voltage V	Setpoint °C
Heating Minimum	4.5	25
Heating Maximum	7.0	50
Cooling Minimum	1.0	-10
Cooling Maximum	4.0	20

Altherma*	Voltage V	Setpoint °C
Heating Minimum	4.5	25
Heating Maximum	10.0	80
Cooling Minimum	2.5	5
Cooling Maximum	4.0	20

* Not applicable in Room Temperature Control mode

Modbus Protocol

MODBUS CONFIGURATION

Network	3 wire RS485
Mode	Modbus RTU Slave
Baud	9600*
Parity	None*
Stop bits	1
Register Base	0

*RTD interfaces can be configured with different baud rate and parity settings if required

Modbus address range 0 to 63 set using SW1 (Figure 6).

Details of the Modbus Protocol can be found in the **Modicon Modbus Protocol Reference Guide** available on the internet.

MODBUS REGISTERS

The RTD-W supports two types of register, analogue *Holding Registers* and analogue *Input Registers*. Register Addresses are '0' based in the range 0..65535.

Register Type	Access	Function
Holding Register	Read/Write	Control and Command Registers
Input Register	Read Only	Readback and Monitoring Registers

All analogue and digital values are accessed through these registers. All register values are 2 byte (16 bit) values except where otherwise indicated.

Different data types are returned using the following conventions

Data Type	Range	Convention
Digital	0..1	=0 : FALSE, <0 : TRUE
16 bit Integer (signed)	-32768..32767	Two's complement
16 bit Integer (unsigned)	0..65535	No scaling required
32 bit Integer (unsigned)	0..4294967295	Stored in two consecutive registers R,R+1 R contains the High 16 bit Word R+1 contains the Low 16 bit Word
x100 Temperature	-327.68..327.67	Temperatures values are generally returned <i>multiplied by 100</i> to allow greater precision. To allow for negative temperature the value is returned as a <i>signed integer</i> , this means that any value greater than 32767 must be converted into a negative value by subtracting 65536. Examples: A readback value of 2150 is a positive temperature so: $2150 / 100 = 21.50^{\circ}\text{C}$ A readback value of 65036 is a negative temperature so: $65036 - 65536 = -500$ $-500 / 100 = -5.00^{\circ}\text{C}$

Registers are accessed using standard Modbus functions. The following four functions are supported by the RTD interface.

Function Code (hex code)	Function Name	Register Count
03 (03h)	Read Holding Registers	1..10
04 (04h)	Read Input Registers	1..10
06 (06h)	Preset Single Holding Register	1

16 (10h)	Preset Register	Multiple Holding	1..10
----------	-----------------	------------------	-------

In this document, Holding registers are written as **H0010** where 'H' indicates *Holding* register and '0010' indicates the register address 0010. Similarly Input registers are referred to as **I0010** where 'I' indicates an *Input* register

Control Functions

UNIT CONTROL

Unit Control functions are available in Holding Registers **H0001** to **H0012**. All Unit Control Registers can be treated as *signed 16 bit integers*.

Holding Register	Name	Range
H0001	Leaving water setpoint in heating mode	25~80°C for HT-Altherma hydrobox 25~50°C for inverter chiller
H0002	Leaving water setpoint in cooling mode	5~20°C for HT-Altherma hydrobox -10~20°C for inverter chiller
H0003	Operation Mode	1..2 (1=Heating, 2=Cooling)
H0004	Modbus ON/OFF space heating or cooling	0..1 (0:Off, 1:On)
H0005	Room Temperature Setpoint	16~32°C
H0006	Modbus Domestic Hot Water reheat	0..1 (0:Off, 1:On)
H0007	Start Domestic Hot Water storage	0..1 (0:Idle, 1:Start)

H0008	Operation mode and ON/OFF control source	1..3 (1:External, 2:Local, 3: On Change)
H0009	Quiet mode operation	0..1 (0:Disable, 1:Enable)
H0010	Weather dependent setpoint operation	0..1 (0:Disable, 1:Enable)
H0011	Shift value leaving water temperature SP during weather dependent setpoint operation	-5..+5 Degrees C
H0012	Reset Run Hour Counter	(55555 = Reset)

The available functions depend on the functions available on the attached equipment. Any control fields that are not available will return a value of 32767 and Modbus commands sent to these registers will have no effect.

ON/OFF COMMANDS

Modbus Heating/Cooling On/Off and Domestic Hot Water (DHW) Reheat registers operate in conjunction with commands from physical inputs and Remcon state.

Holding Register **H0008** determines the source of control commands. The default operating mode is **On Change**, this allows Space Heating and DHW On/Off commands to be sent from the Remcon, Modbus input or S Sensor Inputs. An input change from any source will cause the On/Off state of the unit to change.

Value	Input Control Source	Remcon	Modbus	S Inputs
1	External	NO	YES	YES
2	Local	YES	NO	NO
3	On Change (Default)	YES	YES	YES

If the Input Control Source is set to **Local** (value = 2) then only commands from the Remcon will be accepted. If the Input Control

Source is set to **External** (value = 1) then only commands from the Modbus or Sensor Inputs will be accepted and commands from the Remcon will be overridden.

GROUP READBACK

The following input registers give common readback values for unit operation.

Input Register	Name	Range
I0020	P1P2 PCB Count	0..16
I0021	Group ERROR	0..1 (0:No Error, 1:Error)
I0022	Group ERROR Code	RTD ASCII Format*
I0036	Group ERROR sub code	0..99
I0023	Average leaving water temperature of the group	x100 Temperature
I0050	Remcon Room temperature	x100 Temperature
I0070	ON/OFF space heating or cooling	0..1 (0:Off, 1:On)
I0071	Circulation pump operation	0..1 (0:Off, 1:On)
I0072	Compressor Run	0..1 (0:Off, 1:On)
I0074	Disinfection operation	0..1 (0:Off, 1:Busy)
I0075	Setback operation	0..1 (0:Off, 1:Busy)
I0076	Defrost/start up mode	0..1 (0:Off, 1:Busy)
I0077	Domestic hot water reheat	0..1 (0:Off, 1:Busy)
I0078	Domestic hot water storage	0..1 (0:Not busy, 1:Busy)
I0080	Pump Running Hours Accumulated	High 16 bit Word
I0081	Pump Running Hours Accumulated	Low 16 bit Word

*RTD ASCII Fault Code generation functions are documented in the 'RTD-NET Installation Instructions' available at www.realtime-controls.co.uk/rtd

For Error code and sub codes refer to manufacturer Service Manual

The Pump Running Hours value is a Non-Volatile value stored in the RTD and retained if the RTD is powered down. The value can be reset to zero by writing a value of 55555 to H0012.

UNIT READBACK

Each PCB on the P1P2 network can be monitored for additional function data. Input registers numbered in the range I0100 to I1699 contain the individual PCB readback data where the first two digits xx of Ixx00 correspond to the PCB number 01 to 16.

Input Register xx = 01..16	Name	Range
Ixx22	Group ERROR Code	RTD ASCII Format
Ixx36	Group ERROR sub code	0..99
Ixx44	System Code	ASCII Character
Ixx45	Type Code	ASCII Character
Ixx46	Series Code	ASCII Character
Ixx47	Capacity Code	0..251
Ixx23	Leaving Water Temperature	x100 Temperature
Ixx31	Return Water Temperature	x100 Temperature
Ixx32	DHW Tank Temperature*	x100 Temperature
Ixx33	Outdoor Temperature	x100 Temperature

*Valid where feature is available

Sensor Input Registers

Input Register	Sensor	Name	Range
I10001	S1	Space Heating On	0..1 (0:Off, 100:On)
I10002	S2	Space Cooling On	0..1 (0:Off, 100:On)
I10003	S3	DHW Reheat Disable	0..1 (0:Off, 100:On)
I10004	S4	Enable Quiet Mode	0..1 (0:Off, 100:On)
I10005	S5	SPARE	Not in use
I10006	S6	Space Heating/Cooling Setpoint	0..1000 (Voltage x 100)